

COLDEX
compressors

TD80 VS

**Compressor for R134a 12/24V DC
Technical specifications**

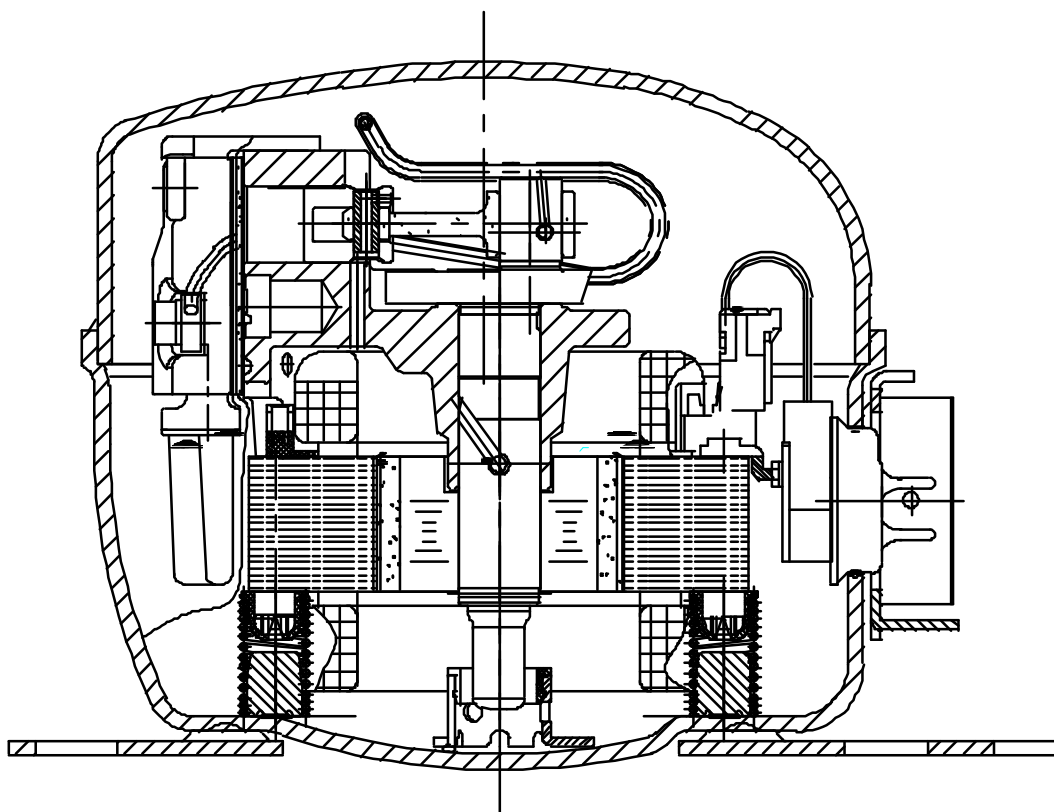

Thanks for choosing the **TD80 VS** R134a 12/24V DC compressor.
Please read this manual thoroughly before beginning operation.

1 About the product

Suitable for the cooling device with a power of 12 or 24V DC power supply, Evaporating Temperature at -35 °C/-5 °C, especially for using in a mobile applications, the refrigerant is R134a.

2 Features

- 2.1. Easy start, High efficiency.
- 2.2. Low noise, Low vibrancy, Long life cycle.
- 2.3. Attached Controller, Few attachment, Easy to use.
- 2.4. Rotary speed at 2000 rpm /3500rpm adjustable.

3 Type

Hermetic reciprocating refrigeration compressor.

4 Technical Data

Table 1 Specification

Compressor Model		COLDEX TD80 VS			
Displacement	cm ³	3.5			
Application		LBP			
Rotation	rpm	2000	2500	3000	3500
Capacity	W	60	75	90	105
Input Voltage	W	50	62.5	75	87
Voltage range	A	2.1/4.2*	2.6/5.2*	3.1/6.2*	3.6/7.2*
COP	W/W	1.2			
Sound Level	dB(A)	40			
Vibrancy Acceleration	m/s ²	= 0.70			
Operating Voltage	V DC	10.9V /17V(12V) 22.7V /31.5V(24V)			
Cooling		Static or Fan cooling			
Lubricant		Polyester			
Lube Vol.	ml	180±5			
Weight	kg	4.5			
Weight of Controller	kg	0.35			
Motor Type		BLDCM			
Refrigerant		R134a			
Throttling Device		Capillary			
Power Supply	V D C	12/24			
Test conditions:	Evaporating Temp .	- 23.3°C	Suction. Temp.	32.2° C	
	Condensing Temp.	54.4 ° C	Sub-coolin g Temp.	32.2°C	
	Ambient Temp.	32.2 °C			
Notes:	** *base on the input voltage 12V DC				

5 Controller

5.1 Wiring

The **TD80 VS** Compressors are fixed with a brushless direct current motor which is controlled by electronically communicated Attached Controller, the wiring is showed as the following drawing:

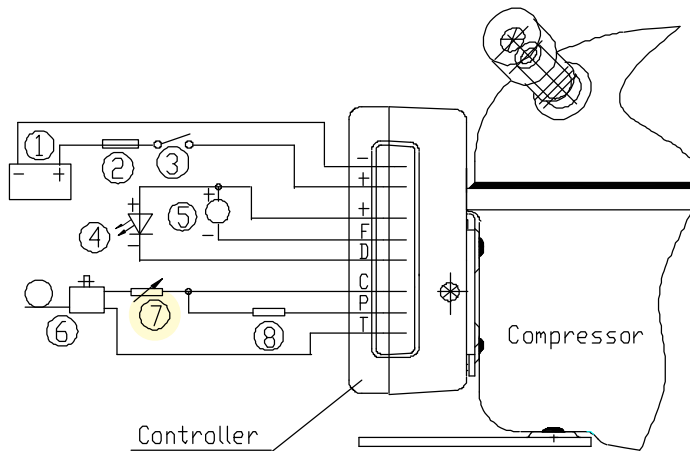

The components are as follow:

- 1 Battery
- 2 Fuse
- 3 Main Switch (optional)
- 4 LED (optional)
- 5 12V DC Cooling Fan (optional)
- 6 Thermostat
- 7 Resistor for presetting speed (optional) C-T
- 8 Resistor for presetting battery protection voltage (optional) C-P

- 5.1.1 The Controller is connected to the battery directly, wrong connect the poles doesn't destroy the compressor and controller, but the compressor do not work;
- 5.1.2 The fuse must be connected in the + cable to protect controller, which close to the power supply, 15A fuse for 12VDC and 7.5 A fuse for the 24VDC are recommended;
- 5.1.3 If a main switch is used, it should be rated to current of min. 20A;
- 5.1.4 To prevent voltage dropping, please avoid extra junction in the power supply system.
- 5.1.5 A Light Emitting Diode(LED) for compressor operation monitoring can be connected between the terminals + and D .
Operational errors will cause the LED to flash a number of times. The number of flashes depends on what kind of operational error was recorded. Each flash will last 1/4 second and each error will repeat every 4 seconds. Operational errors show by Table 5, please see it in page 6.
- 5.1.6 If a cooling fan is used. It must be connected to electronic unit terminals+ and F, only use 12VDC fan , no matter what power supply you are using;
- 5.1.7 A Thermostat is connected between the terminal C and T of the electronic unit. It will start or stop the running of compressor automatically;
- 5.1.8 A Resistor can be connected between terminal C and T, it allows you to adjust the speed of the compressor, the relationship between the resistor and the compressor speed shown by Table 3; please see it in page 3.
- 5.1.9 To ensure sufficient battery power for compressor and avoid permanent damage to the battery because heavy discharge. A battery protection resistor is connected between terminal C and P, the different resistor will get the different voltage protection, the details is showed by Diagram 4;

5.2 The Technical Specification of controller is shown:



Table 2 Controller Data

Compressor Model		COLDEX <i>TD80 VS</i>
Controller	Model	12-24 V AUTO
	Dimensions	116mm X 103mm X 50mm
	Output Power, W	20W~ 140W
	Static Consumption Power, W	= 2
	Max. Ambient Temp., ?	55
	Max. Operating Current, A	= 12A(12V) = 6A(24V)
	Startup Time, S	= 6s (to 1850rpm)

5.3 Compressor Speed Setting:

The speed of compressor can be adjusted in a range of 2000rpm ~ 3500rpm by adjusting the resistor of presetting speed:

Table 3 Speed Setting (Terminal C-T)

	Resistor Ω	Speed rpm
	0	2000
White Resistor 	277	2500
Black Resistor 	692	3000
Red Resistor 	1523	3500

5.4 Standard Battery Protection Setting:

Table 4 Battery Protection Setting ± 0.1 V (Terminal C-P)

Protect Resistor (K &)	12V cut-out (V)	12V cut-in (V)	12V Max. Voltage (V)	24V cut-out (V)	24V cut-in (V)	24V Max. voltage (V)
0	9.6	10.9	17.0	21.3	22.7	31.5
1.6	9.7	11.0	17.0	21.5	22.9	31.5
2.4	9.9	11.1	17.0	21.8	23.2	31.5
3.6	10.0	11.3	17.0	22.0	23.4	31.5
4.7	10.1	11.4	17.0	22.3	23.7	31.5
6.2	10.2	11.5	17.0	22.5	23.9	31.5
8.2	10.4	11.7	17.0	22.8	24.2	31.5
11	10.5	11.8	17.0	23.0	24.5	31.5
14	10.6	11.9	17.0	23.3	24.7	31.5
18	10.8	12.0	17.0	23.6	25.0	31.5
24	10.9	12.2	17.0	23.8	25.2	31.5
33	11.0	12.3	17.0	24.1	25.5	31.5
47	11.1	12.4	17.0	24.3	25.7	31.5
82	11.3	12.5	17.0	24.6	26.0	31.5
220	9.6	10.9	Photovoltaic solar application			31.5

Controller calibrator to the operating voltage automatically, when the battery voltage is lower than 17 VDC, the controller is working at a 12 VDC system automatically when the voltage is higher than 17 V DC the controller is working at a 24 VDC system automatically. If a 220K Ω resistor is connected between terminals C-P the operating voltage range could be extended between 9.6V ~ 31.5V, this means **TD80 VS** is very suitable for photovoltaic solar power application.

5.5 Error Indication

Operational errors will cause the LED to flash a number of times. The errors is showed by table 5. Each flash will last ¼ second. After the actual number of flashes there will be a delay with no flashes, so that the sequence for each error recording is repeated every 4 seconds. The operational errors shown by LED(optional).

Table 5 LED Error Indications

Number of flashes	Error Type
5	Thermal cut-out of controller (If the refrigeration system has been too heavily loaded, or if the ambient temperature is higher than 55°C controller will run too hot)
4	Minimum motor speed error (if the refrigeration system is too heavily loaded, the motor speed is lower than 1850 rpm)
3	Motor start error (The rotor is blocked or the differential pressure of the refrigeration system is higher than 5 bar)
2	Fan over-current cut-out (The operating current of cooling fan is more than 1A)
1	Battery protection cut-out (Battery Voltage is outside the setting range shown in Table 4)

6 Accessories

Table 6 Accessories

No.	Title	Pieces	Model	Comments
1	Controller	1	12 – 24 volt AUTO	
2	Screw of controller	1	(M4×8)	
3	Rubber grommet	4	RU HC 35-50-80	Base on the demand of users
4	Grommet sleeve	4	SL HC 35-50-80	

7 Transportation and storage

- 7.1 Please keep the **TD80 VS** compressor perpendicularity, can not be turned upside down and avoid vibration and shocks during transportation.
- 7.2 The compressors must be mounted in the dry and clean place.
- 7.3 More than two layer package of compressors is not available, and avoid any rolling during loading and unloading.
- 7.4 After consignment, it is better store the compressors not exceeded by 6 months.

8 Precautions

- 8.1 The compressor is only allowed to connect a 12/ 24VDC system, it is forbidden to connect compressor directly with AC power supply.
- 8.2 The back gas tube on refrigeration system must be connected with the suction tube on compressor, not the process tube on it; otherwise the compressor can not work in gear.
- 8.3 Please mount the compressor into the refrigeration system quickly in 10 minutes after uninstall the tubes of the compressor (suggest to uninstall the process tube first).
- 8.4 Balance pressure (55°C: before start the compressor), the pressure in the compressor could not more than 0.49MPa.
- 8.5 Do not operate the compressor before polyester is charged.
- 8.6 The refrigerant charge should be less than 200 g.
- 8.7 The interval of compressor operation: it runs more than 3 minutes, also the stoppage is more than 3 minutes.
- 8.8 Special attention: do not use the compressor as a vacuum pump, and do not start it under vacuum status too.
- 8.9 The refrigeration system should minimize the content of chlorines and moisture which must be free of paraffin and silicon.
- 8.10 To ensure correct start and operating conditions, the following cable dimensions must be observed:

Table 7 Cable requirements

Cross-section mm ²	Max. length between battery and Controller, m	
	12V, DC	24V , DC
2.5	2.5	5
4	4	8
6	6	12
10	10	20

DIMENSION COMPRESSOR COLDEX **TD80 VS**

