

COLDEX
compressors

TD35 VS - TD50 VS

Compressor for R134a 12/24V DC
Technical specifications

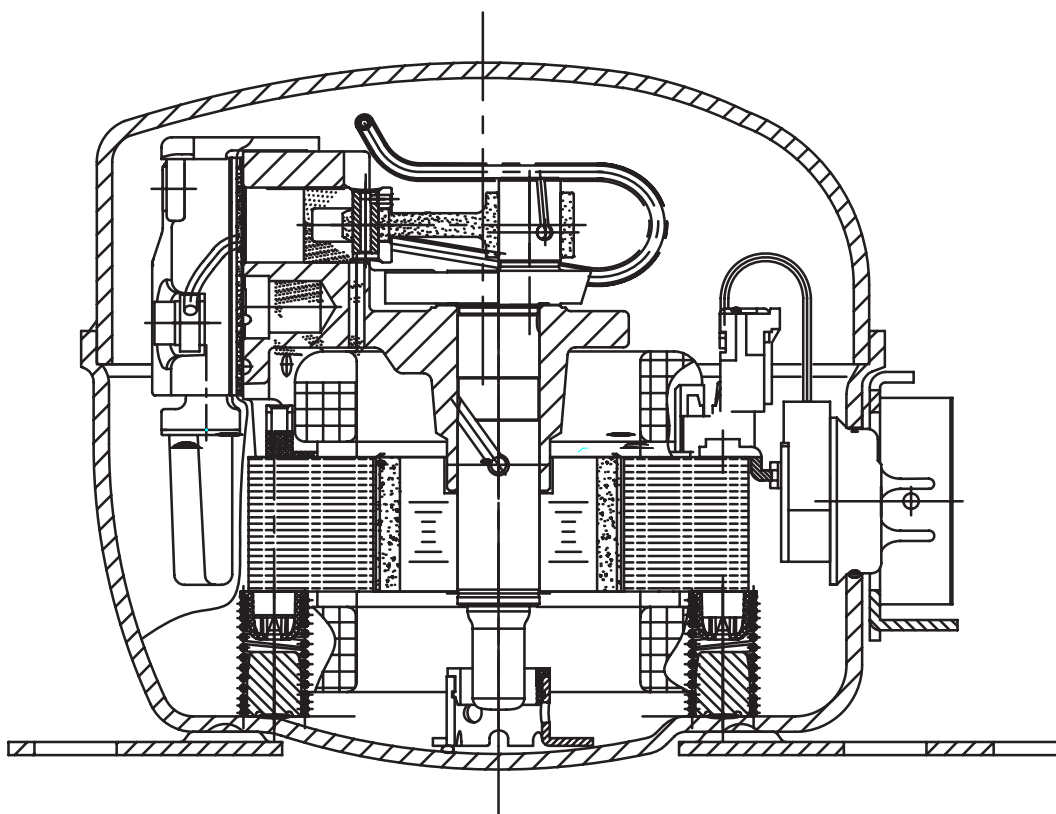

Thank you for choosing the **TD35 VS** and **TD50 VS** R134a 12/24V DC compressor.
Please read this manual thoroughly before beginning operation.

1 Application range

Suitable for the cooling device with a power of 12 or 24V DC power supply, Evaporating Temperature at $-35^{\circ}\text{C} \sim -5^{\circ}\text{C}$, especially for using in a mobile applications, the refrigerant is R134a.

2 Features

- 2.1.Easy start, High reliable.
- 2.2.Low noise, Low vibrancy, long use life.
- 2.3.Attached Controller, Few attachment, Easy to use.
- 2.4.Rotary speed at 2000 rpm \sim 3500rpm adjustable.

3 Type

Hermetic reciprocating refrigeration compressor .

4 Technical Data

Table 1 Specification

COLDEX TD35 VS

Compressor Model	COLDEX TD35 VS			
Displacement, cm^3	2.0			
Applications	LBP			
Rotation, rpm	2000	2500	3000	3500
Capacity, W	33	40	45	50.0
Input Power, W	30	36	41	46.0
Operating Current, A	1.25/2.5*	1.5/3.0*	1.70/3.4*	1.92/3.8*
C.O.P , W/W	1.1			
Sound Level, dB(A)	37			38
Vibrancy Acceleration, m/s^2	≤ 0.65			
Operating Voltage, V DC	10.9V \sim 17V (12V) 、 22.7V \sim 31.5V (24V)			
Cooling	Static or Fan cooling			
Lubricant	Polyester			
Lube Vol. , ml	150 \pm 5			
Weight , kg	4.3			
Weight of Controller, kg	0.40			
Motor Type	BLDCM			
Refrigerant	R134a			
Throttling Device	Capillary			
Power, V D C	12/24			
Test conditions:	Evaporating Temp.	-23.3 $^{\circ}\text{C}$	Suction. Temp.	32.2 $^{\circ}\text{C}$
	Condensing Temp.	54.4 $^{\circ}\text{C}$	Sub-cooling Temp.	32.2 $^{\circ}\text{C}$
	Ambient Temp.	32.2 $^{\circ}\text{C}$		
Notes: “*” base on the input power of 12V DC				

Table 1.1 Specification

COLDEX TD50 VS

Compressor Model	COLDEX TD50 VS			
Displacement, cm ³	2.5			
Applications	LBP			
Rotation, rpm	2000	2500	3000	3500
Capacity, W	42	52	61	71
Input Power, W	38.2	47.3	55.5	64.5
Operating Current, A	1.5/3.0*	1.9/3.8*	2.3/4.6*	2.7/5.4*
C.O.P , W/W	1.1			
Sound Level, dB(A)	38			40
Vibrancy Acceleration, m/s ²	≤0.65			
Operating Voltage, V DC	10.9V~17V (12V) 、 22.7V~31.5V (24V)			
Cooling	Static or Fan cooling			
Lubricant	Polyester			
Lube Vol. , ml	150 ± 5			
Weight , kg	4.3			
Weight of Controller, kg	0.40			
Motor Type	BLDCM			
Refrigerant	R134a			
Throttling Device	Capillary			
Power, V D C	12/24			
Test conditions:	Evaporating Temp.	-23.3 °C	Suction. Temp.	32.2 °C
	Condensing Temp.	54.4 °C	Sub-cooling Temp.	32.2 °C
	Ambient Temp.	32.2 °C		
Notes: “*” base on the input power of 12V DC				

5 Controller

5.1 Wiring

The Compressors **TD35 VS** and **TD50 VS** are equipped with a brushless direct current motor which is controlled by an Attached Controller, the wiring is shown as following drawing:

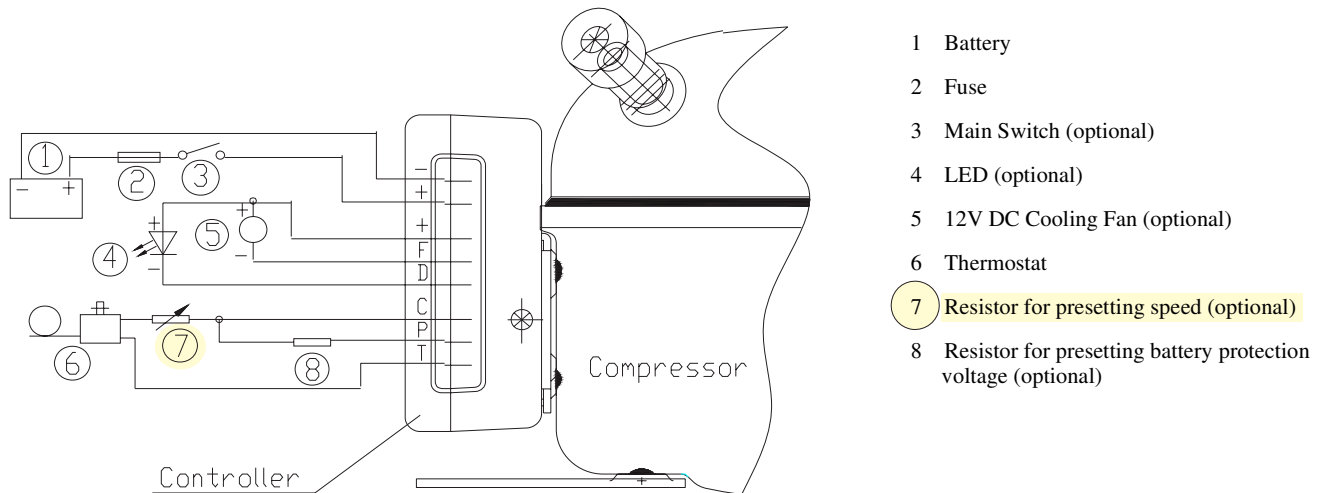

5.1.1 The Controller is connected to the battery directly, wrong connect the poles doesn't destroy the compressor and controller, but the compressor do not work;

5.1.2 The fuse must be connected in the + cable to protect controller, which close to the power supply, 15A fuse for 12VDC and 7.5A fuse for the 24VDC are recommended;

5.1.3 If a main switch is used, it should be rated to current of min. 20A;

5.1.4 To prevent voltage dropping, please avoid extra junction in the power supply system.

5.1.5 A Light Emitting Diode(LED) for compressor operation monitoring can be connected between the terminals + and D .

Operational errors will cause the LED to flash a number of times. The number of flashes depends on what kind of operational error was recorded. Each flash will last 1/4 second and each error will repeat every 4 seconds. Operational errors show by Table 5, please see it in page 6.

5.1.6 If a cooling fan is used. It must be connected to electronic unit terminals + and F, only use 12VDC fan , no matter what power supply you are using;

5.1.7 A Thermostat is connected between the terminal C and T of the electronic unit. It will start or stop the running of compressor automatically;

5.1.8 A Resistor can be connected between terminal C and T, it allows you to adjust the speed of the compressor, the relationship between the resistor and the compressor speed shown by Table 3; please see it in page 3.

5.1.9 To ensure sufficient battery power for co mpessor and avoid permanent damage to the battery because heavy discharge. A battery protection resistor is connected between terminal C and P, the different resistor will get the different voltage protection, the details is showed by Diagram 4;

5.2 The Technical Specification of controller is shown:

Table 2 Controller Data

Compressor Model		<i>TD35 VS - TD50 VS</i>
Controller	Model	12/24V DC
	Dimensions	116mm × 103mm × 50mm
	Output Power, W	20W~ 140W
	Static Consumption Power, W	≤2
	Max. Ambient Temp., °C	55
	Max. Operating Current, A	≤12A (12V), ≤ 6A(24V)
	Startup Time, S	≤6s (to 1850rpm)

5.3 Compressor Speed Setting:

The compressor's speed could be adjusted in range 2000rpm ~3500rpm by adjusting the resistor of presetting speed:

Table 3 Speed Setting

Resistor Ω	Speed rpm
0	2000
277	2500
692	3000
1523	3500

5.4 Battery Protection Setting:

Table 4 Battery Protection Setting

Protect Resistor (KΩ)	12V cut-out (V)	12V cut-in (V)	12V Max. Voltage (V)	24V cut-out (V)	24V cut-in (V)	24V Max. voltage (V)
0	9.6	10.9	17.0	21.3	22.7	31.5
1.6	9.7	11.0	17.0	21.5	22.9	31.5
2.4	9.9	11.1	17.0	21.8	23.2	31.5
3.6	10.0	11.3	17.0	22.0	23.4	31.5
4.7	10.1	11.4	17.0	22.3	23.7	31.5
6.2	10.2	11.5	17.0	22.5	23.9	31.5
8.2	10.4	11.7	17.0	22.8	24.2	31.5
11	10.5	11.8	17.0	23.0	24.5	31.5
14	10.6	11.9	17.0	23.3	24.7	31.5
18	10.8	12.0	17.0	23.6	25.0	31.5
24	10.9	12.2	17.0	23.8	25.2	31.5
33	11.0	12.3	17.0	24.1	25.5	31.5
47	11.1	12.4	17.0	24.3	25.7	31.5
82	11.3	12.5	17.0	24.6	26.0	31.5
220	9.6	10.9	Photovoltaic soalr application			31.5

Controller calibrator to the applied voltage automatically, when the battery voltage is lower than 17 VDC, The controller consider it is working in a 12 V DC system, and When the voltage is higher than 17 VDC The controller consider it is working in a 24 V DC system.

If a 220K Ω resistor is connected between “C” and “T”, the operating voltage range could be extended between 9.6V ~ 31.5V, this means ***TD35 VS*** and ***TD50 VS*** are very suitable for photovoltaic solar power application.

5.5 Error Indication

If the start failed, the controller will attempt restarting every 60s, until a successful start is achieved. The following Table shows the Error Type and reason.

Table 5 LED Error Indications

Number of flashes	Error Type
5	Thermal cut-out of controller (If the refrigeration system has been too heavily loaded, or if the ambient temperature is high than 55°C, the controller will run too hot)
4	Minimum motor speed error (if the refrigeration system is too heavily loaded, the motor speed is lower than 1850 rpm)
3	Motor start error (The rotor is blocked or the system pressure is too high)
2	Fan over-current cut-out (The operating current of cooling fan is more than 1A)
1	Battery protection cut-out (Battery Voltage is outside the setting range shown in Table 4)

6 Accessories

Table 6 Accessories

No.	Title	Pieces	Model	Comments
1	Controller	1	12 - 24 Volt AUTO	
2	Screw of controller	1	(M4 x 8)	
3	Rubber grommet	4	RU HC 35-50-80	
4	Grommet sleeve	4	SL HC 35-50-80	

7 Transportation and storage

- 7.1 Please keep perpendicularity, can not be turned upside down and avoid vibration and shocks during transportation.
- 7.2 Please ensure to store the compressors under dry and well-ventilated condition to avoid the package getting wet.
- 7.3 More than two layer package of compressors is not available, and avoid any rolling during loading and unloading.
- 7.4 After consignment, it is better to store the compressors not more than 6 months.

8 Precautions

- 8.1 The compressor is only allowed to be connected to a 12/24VDC system, it is forbidden to connect compressor directly with an AC power supply.
- 8.2 The back gas tube on refrigeration system must be connected with the suction tube on compressor, not the process tube on compressor; otherwise the compressor can't work in gear.
- 8.3 Please mount the compressor into the refrigeration system quickly in 10 minutes after uninstall the tubes of the compressor (suggest to uninstall the process tube first).
- 8.4 The maximum ambient temperature of the compressor operation is 55 °C. When continuously operating under the maximum ambient temperature 55 °C, the max condensing pressure and the peak pressure should not exceed 1.75MPa and 2.17MPa.
- 8.5 Balance pressure (55 °C): start the compressor, the pressure in the compressor could not more than 0.49MPa.
- 8.6 Do not operate the compressor before polyester is charged.
- 8.7 The refrigerant charge should be less than 200g.
- 8.8 The interval of compressor operation: Operation is more than 3 minutes, and the stoppage is more than 3 minutes too.
- 8.9 Special attention: Do not use the compressor as a vacuum pump, and do not start it under vacuum status too.
- 8.10 The refrigeration system should minimize the content of chlorines and moisture, and must be free of paraffin and silicon.
- 8.11 In order to make the compressor work properly, the following cable dimensions must be observed.

Table 7 Cable requirements

Cross-section mm ²	Max. Length between battery and Controller, m	
	12V, DC	24V, DC
2.5	2.5	5
4	4	8
6	6	12
10	10	20

DIMENSIONS COMPRESSOR

COLDEX TD35 VS - TD50 VS

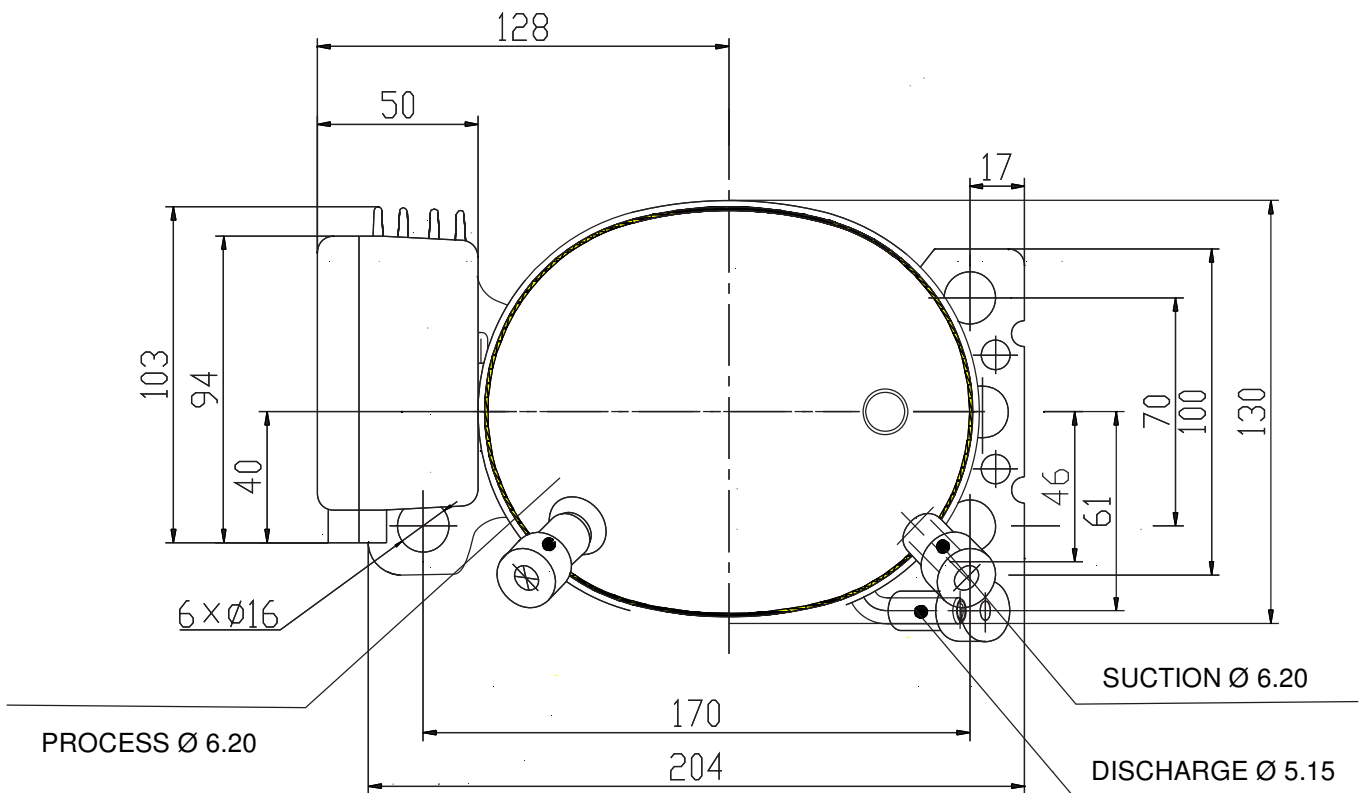
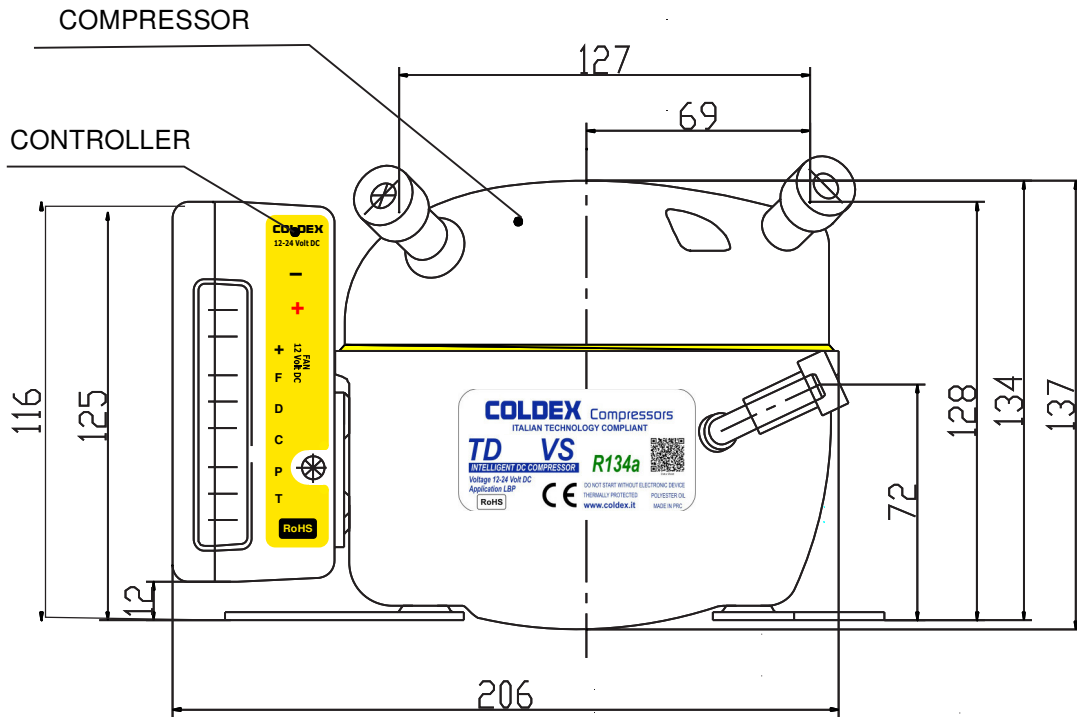

Mounting the controller

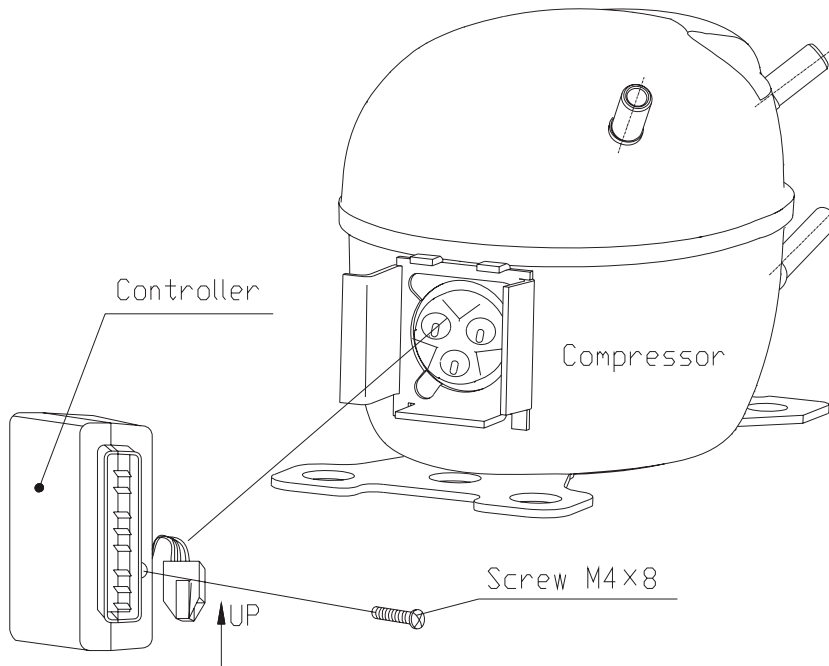

Connection method for refrigeration system

